

# 10" TRAILER PUMP "SEAL"

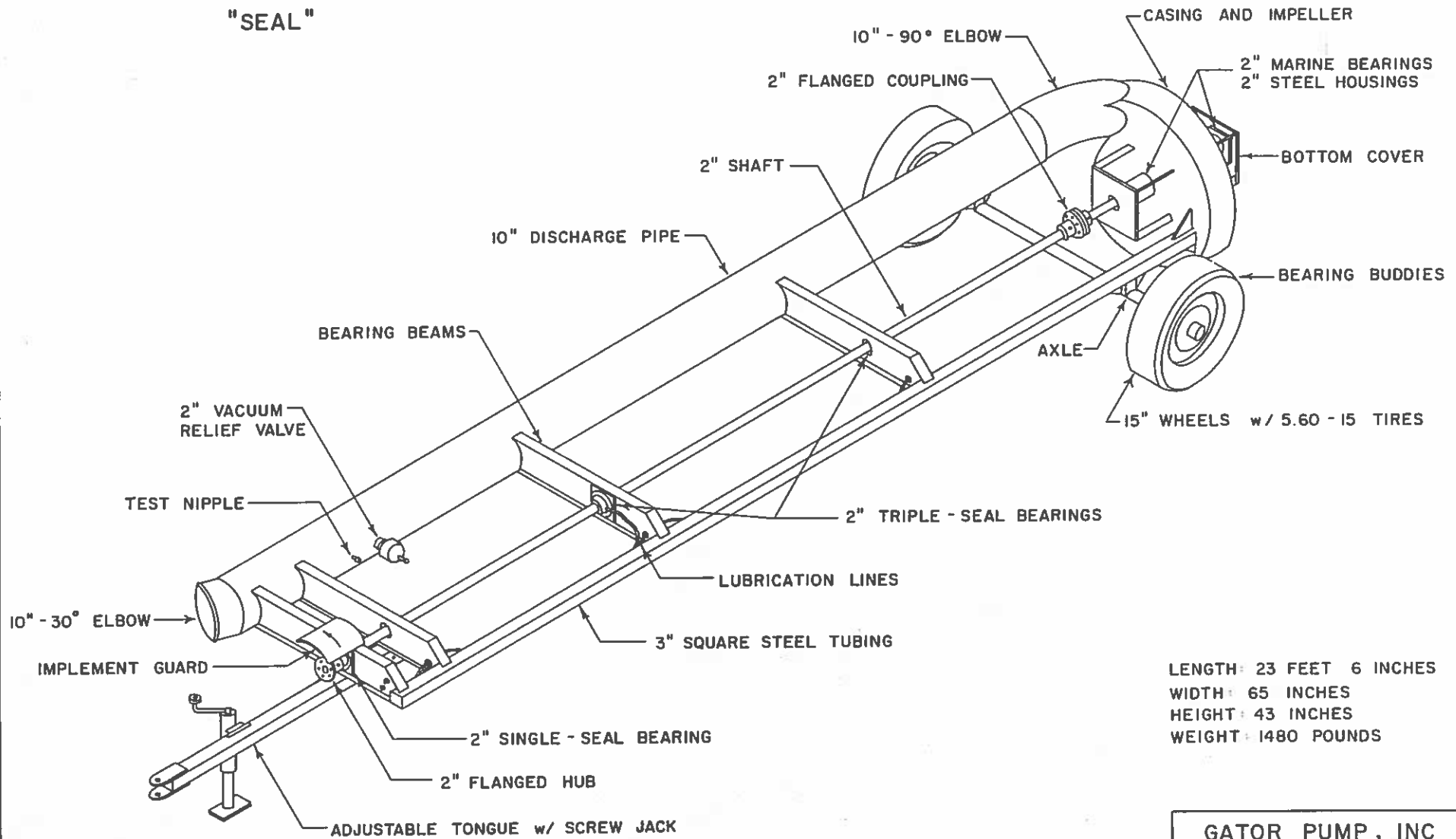

LENGTH: 23 FEET 6 INCHES  
 WIDTH: 65 INCHES  
 HEIGHT: 43 INCHES  
 WEIGHT: 1480 POUNDS

<b>GATOR PUMP, INC</b>			
		SCALE	DRAWN BY
		NTS	FEG
<b>10" TRAILER PUMP, "SEAL"</b>			
DATE	APPROVED BY	DRAWING NUMBER	
7-16-84	<i>Dave Dorell</i>	10T-B	

# GATOR PUMP INC

10/B

TOTAL HEAD  
m ft

SEAL  
PUMP MODEL: 10" TRAILER

IMPELLER DIAMETER: AS SHOWN  
SUCTION DIAMETER: 12" (SINGLE)  
DISCHARGE DIAMETER: 10"  
RPM: 540 (TRACTOR PTO)  
CASING NO.: C-10-B  
IMPELLER NO.: I-1024A  
TEST DATE: 9/6/78

1 US GALLON PER MINUTE =  
3.79 LITERS PER MINUTE  
1 FOOT = .305 METERS  
1 HORSEPOWER = 746 WATTS

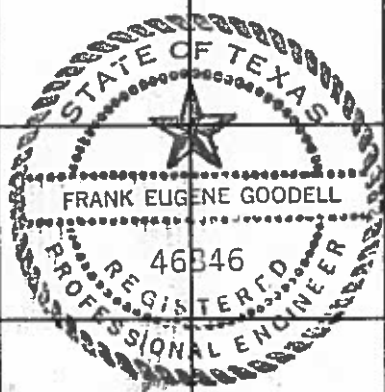
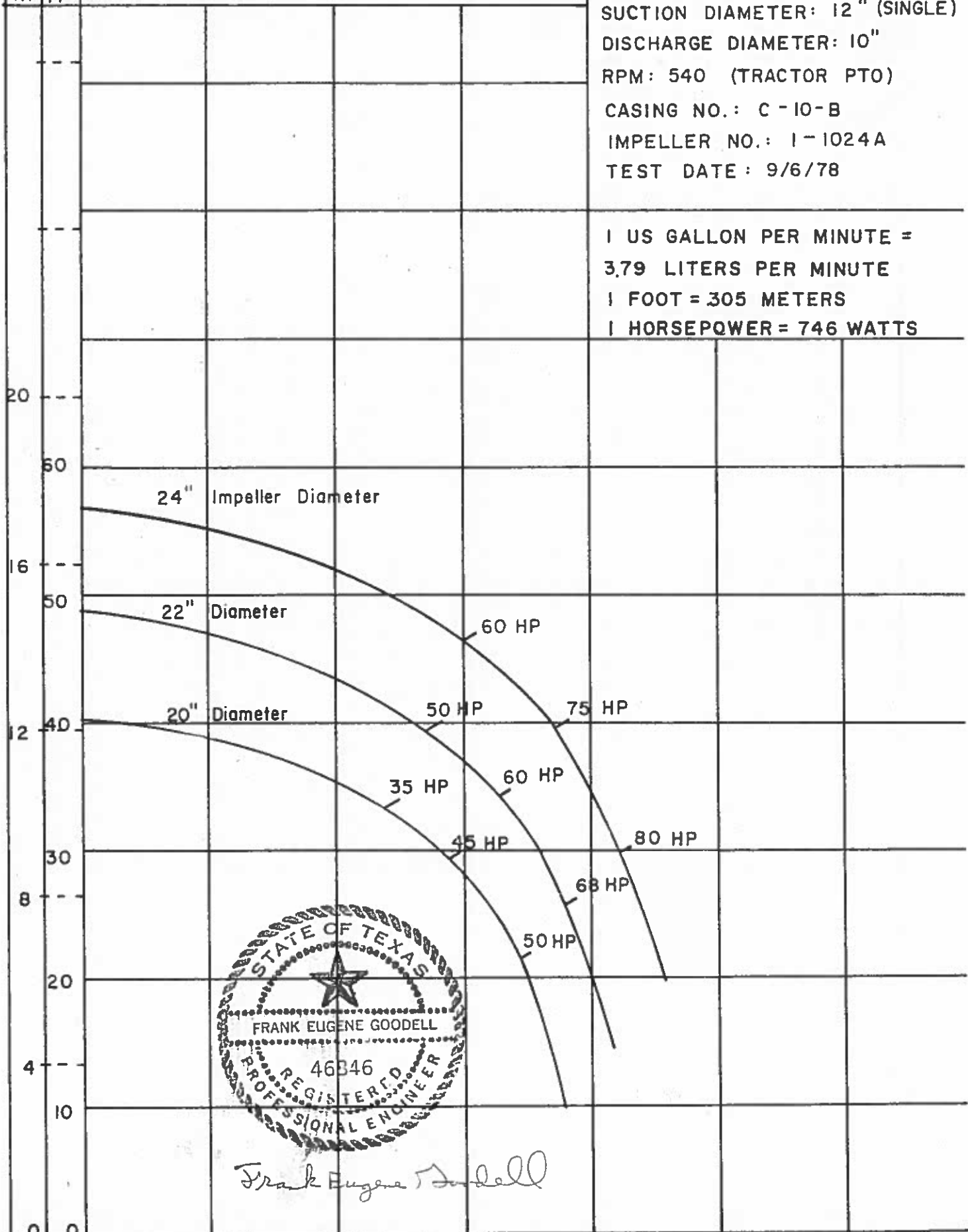

*Frank Eugene Goodell*

Flow Rate: USGPM (0, 1000, 2000, 3000, 4000, 5000) and l/m (0, 1000, 2000, 3000, 4000, 5000)