

12" TRAILER PUMP
"STINGRAY"

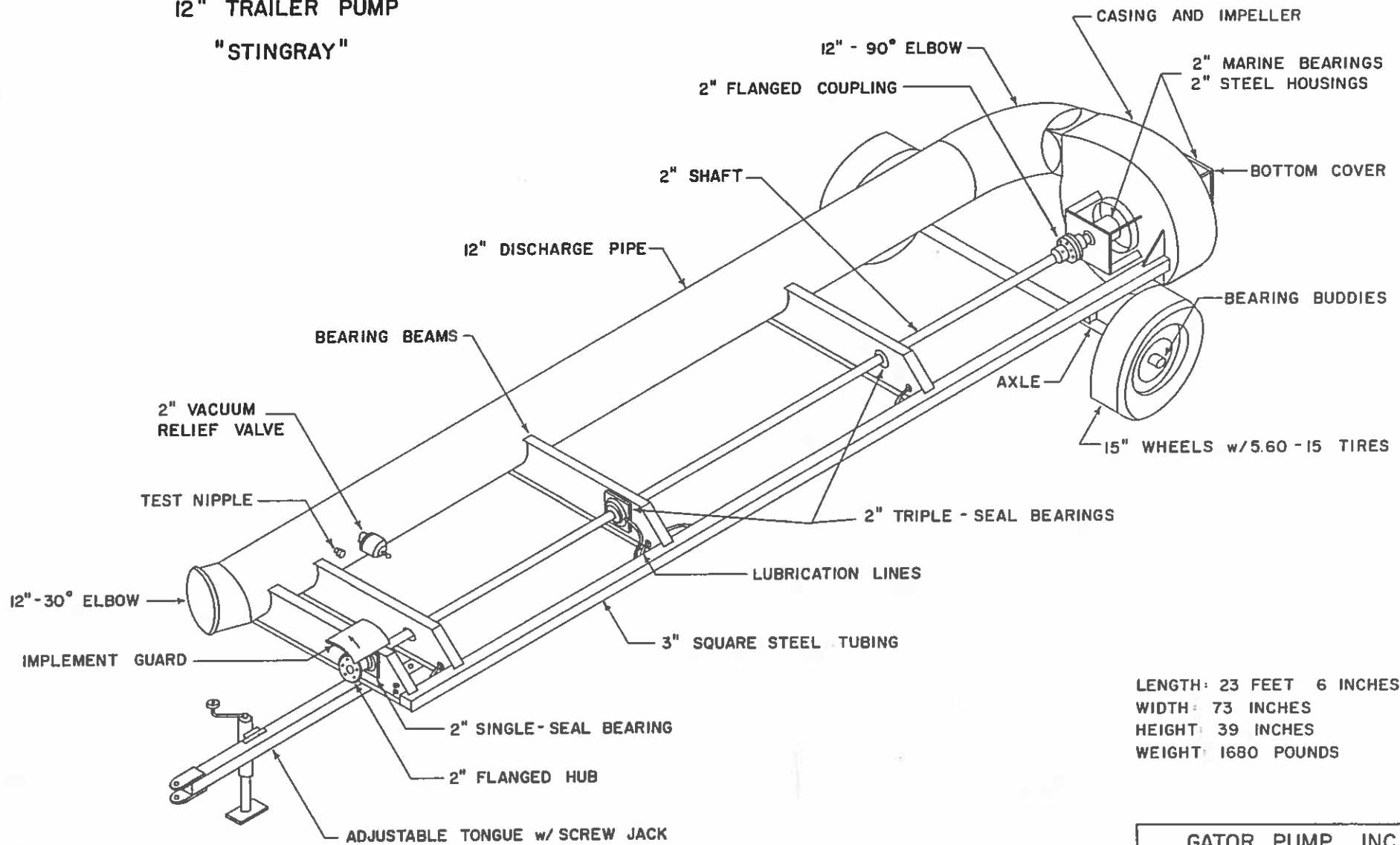

LENGTH: 23 FEET 6 INCHES
 WIDTH: 73 INCHES
 HEIGHT: 39 INCHES
 WEIGHT: 1680 POUNDS

GATOR PUMP, INC.

NTS		DESIGNED BY: FEG
12" TRAILER PUMP, "STINGRAY"		
DATE: 1-21-83	APPROVED BY: <i>Dene J. Dodel</i>	DRAWING NUMBER: 12 T - D

GATOR PUMP, INC

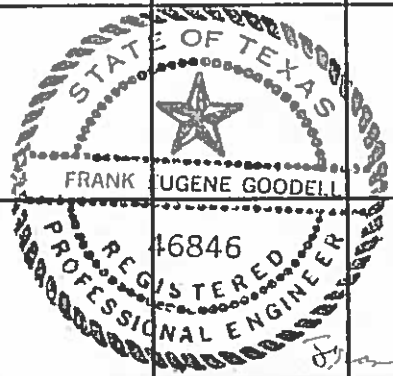
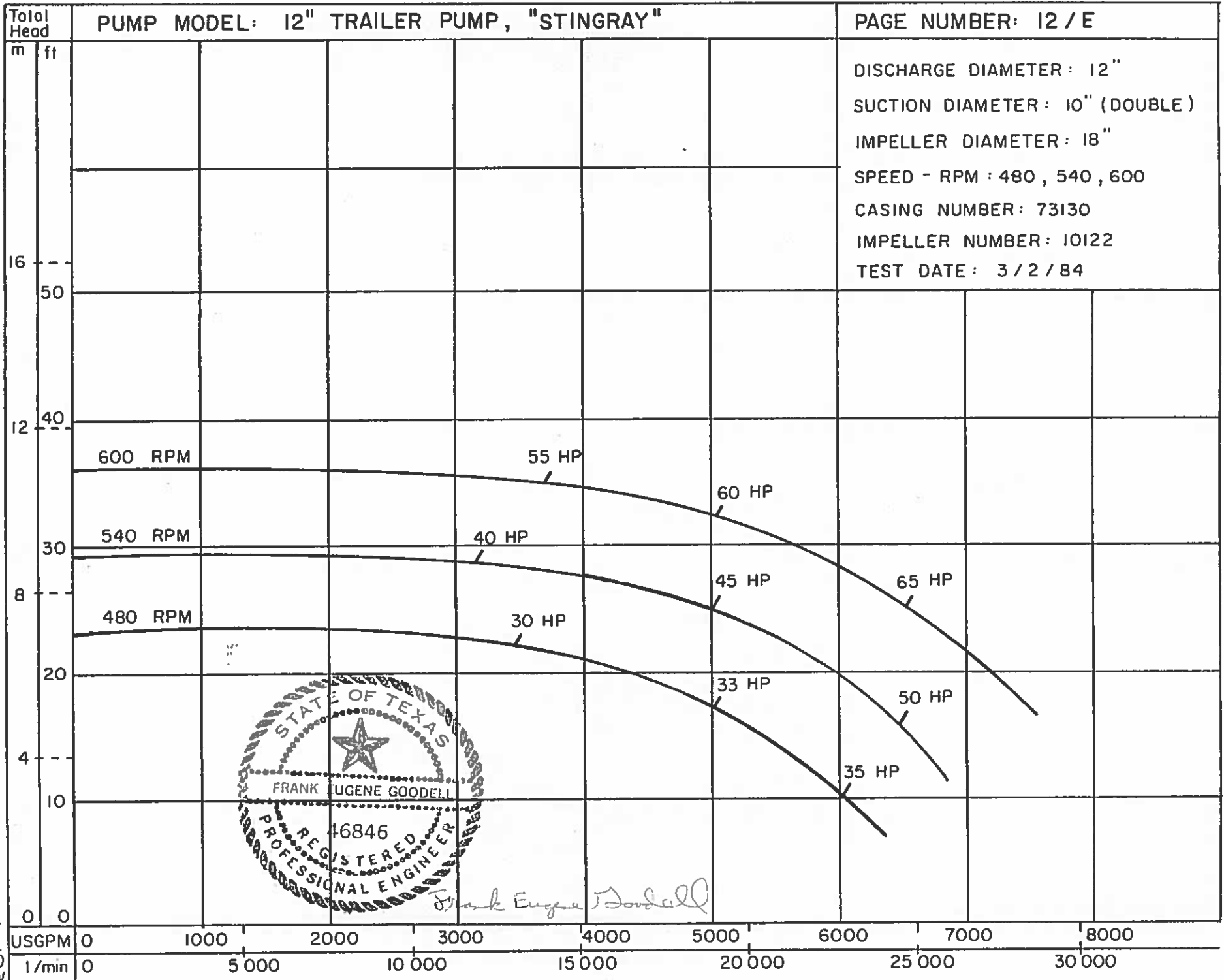

Frank Eugene Goodell

FLOW