

6" TRAILER PUMP  
"MUSKRAT"

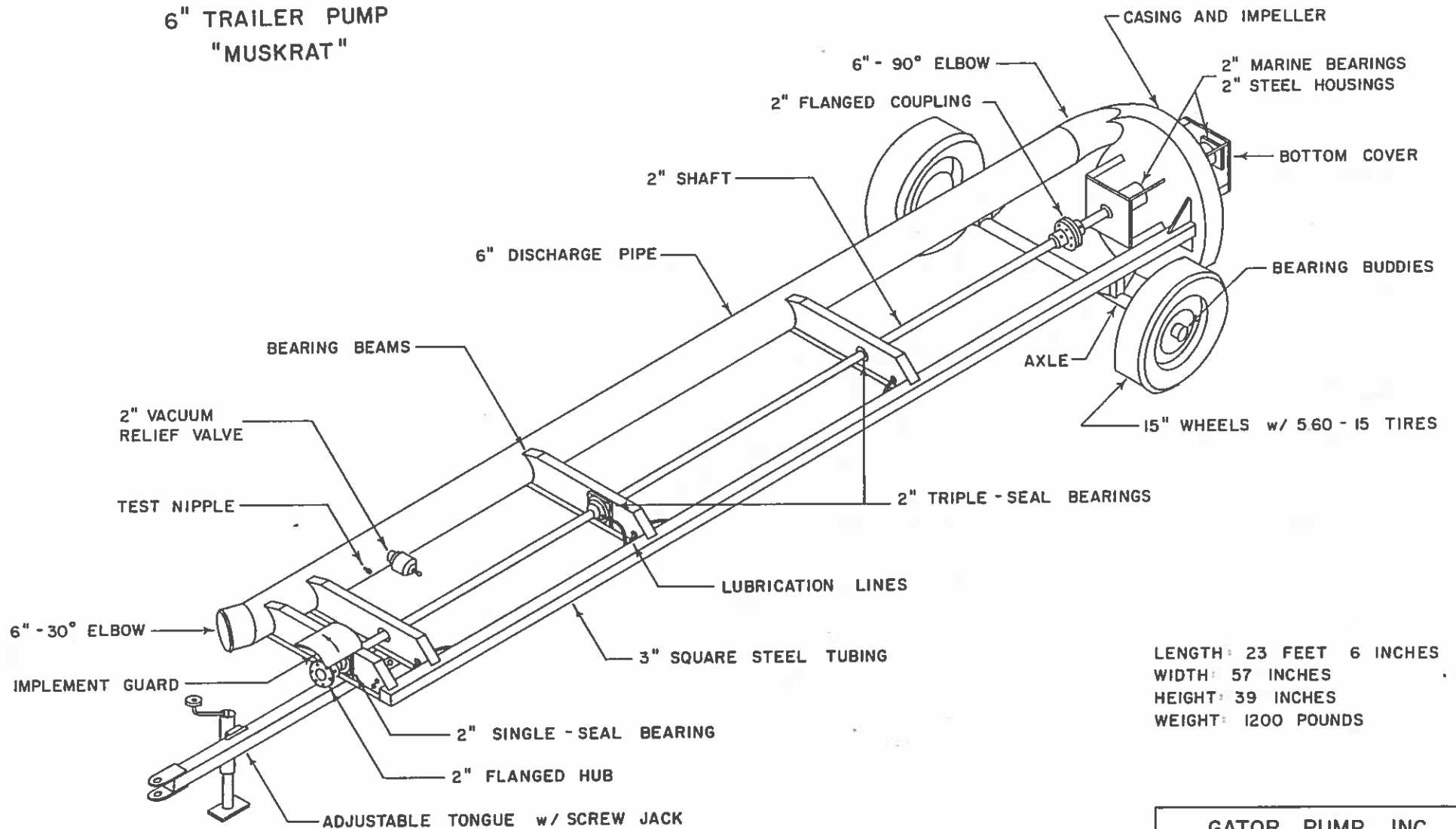

LENGTH: 23 FEET 6 INCHES  
WIDTH: 57 INCHES  
HEIGHT: 39 INCHES  
WEIGHT: 1200 POUNDS

GATOR PUMP, INC.			
SCALE	NTS	DRAWN BY	FEG
DATE		APPROVED BY	DRAWING NUMBER
10-25-84		<i>Gene Dordell</i>	6T-B

# GATOR PUMP INC

6/B

**TOTAL HEAD**  
m ft

**PUMP MODEL:** MUSCRAT  
6" TRAILER PUMP

IMPELLER DIAMETER: 24", 22"  
 SUCTION DIAMETER: 12" (SINGLE)  
 DISCHARGE DIAMETER: 6"  
 RPM: 540 (TRACTOR PTO)  
 CASING NO.: C-06-B  
 IMPELLER NO.: 1-0624A  
 TEST DATE: 10/12/79

1 US GALLON PER MINUTE =  
 3.79 LITERS PER MINUTE  
 1 FOOT = 305 METERS  
 1 HORSEPOWER = 746 WATTS

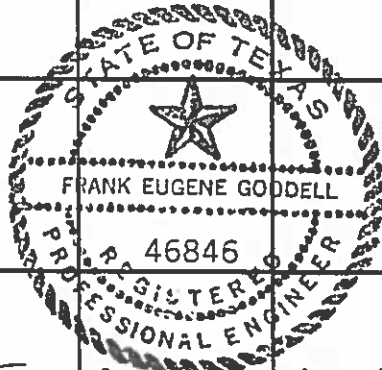
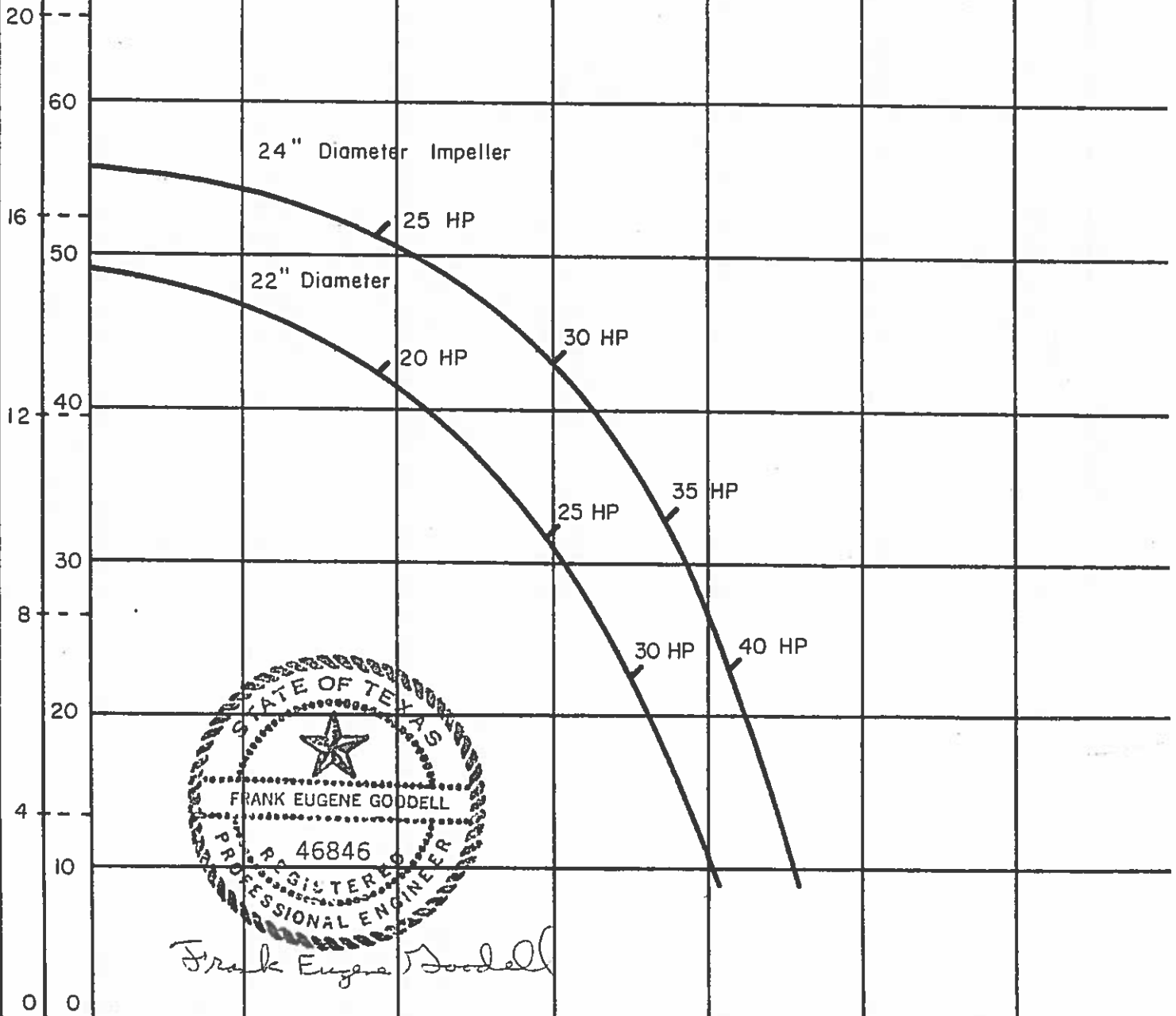

*Frank Eugene Goddell*

USGPM 0 500 1000 1500 2000 2500  
 l/m 0 2500 5000 7500 10000