

# 8" TRAILER PUMP "OTTER"

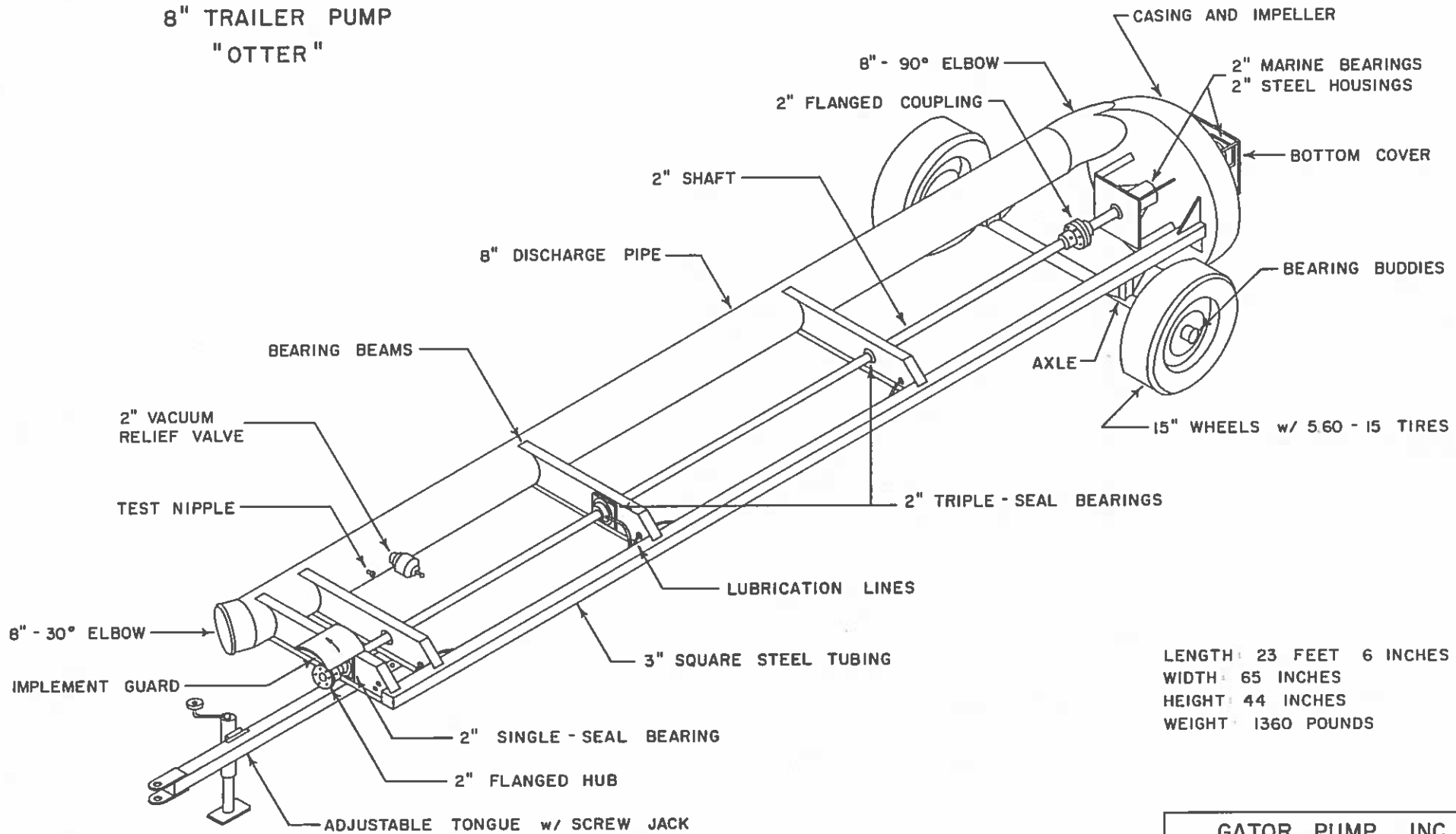

LENGTH: 23 FEET 6 INCHES  
 WIDTH: 65 INCHES  
 HEIGHT: 44 INCHES  
 WEIGHT: 1360 POUNDS

<b>GATOR PUMP, INC.</b>		
SCALE NTS	DRAWN BY FEG	REVISED
<b>8" TRAILER PUMP, "OTTER"</b>		
DATE 10-11-83	APPROVED BY <i>Dene Doodell</i>	DRAWING NUMBER BT-B

# GATOR PUMP, INC

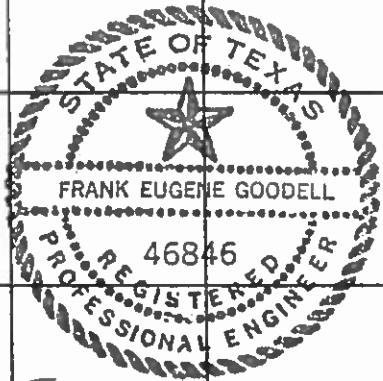
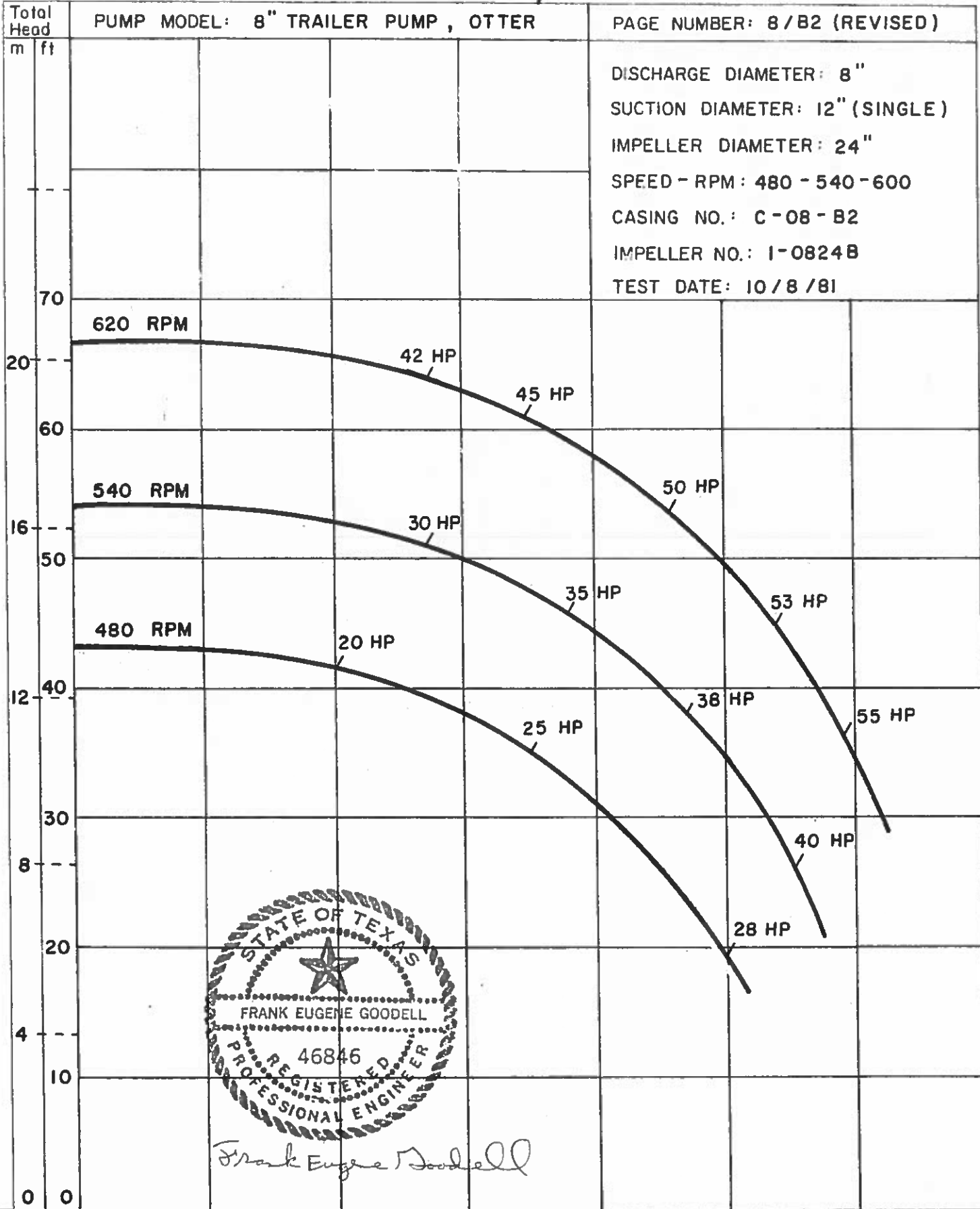

*Frank Eugene Goodell*

FLOW	USGPM	0	500	1000	1500	2000	2500	3000	3500
	l/m	0	2500	5000	7500	10000	12500		